

5

4

3

2

1

ZONE	ECN NO.	REV.	REVISION DESCRIPTION	DATE	APPROVED
------	---------	------	----------------------	------	----------

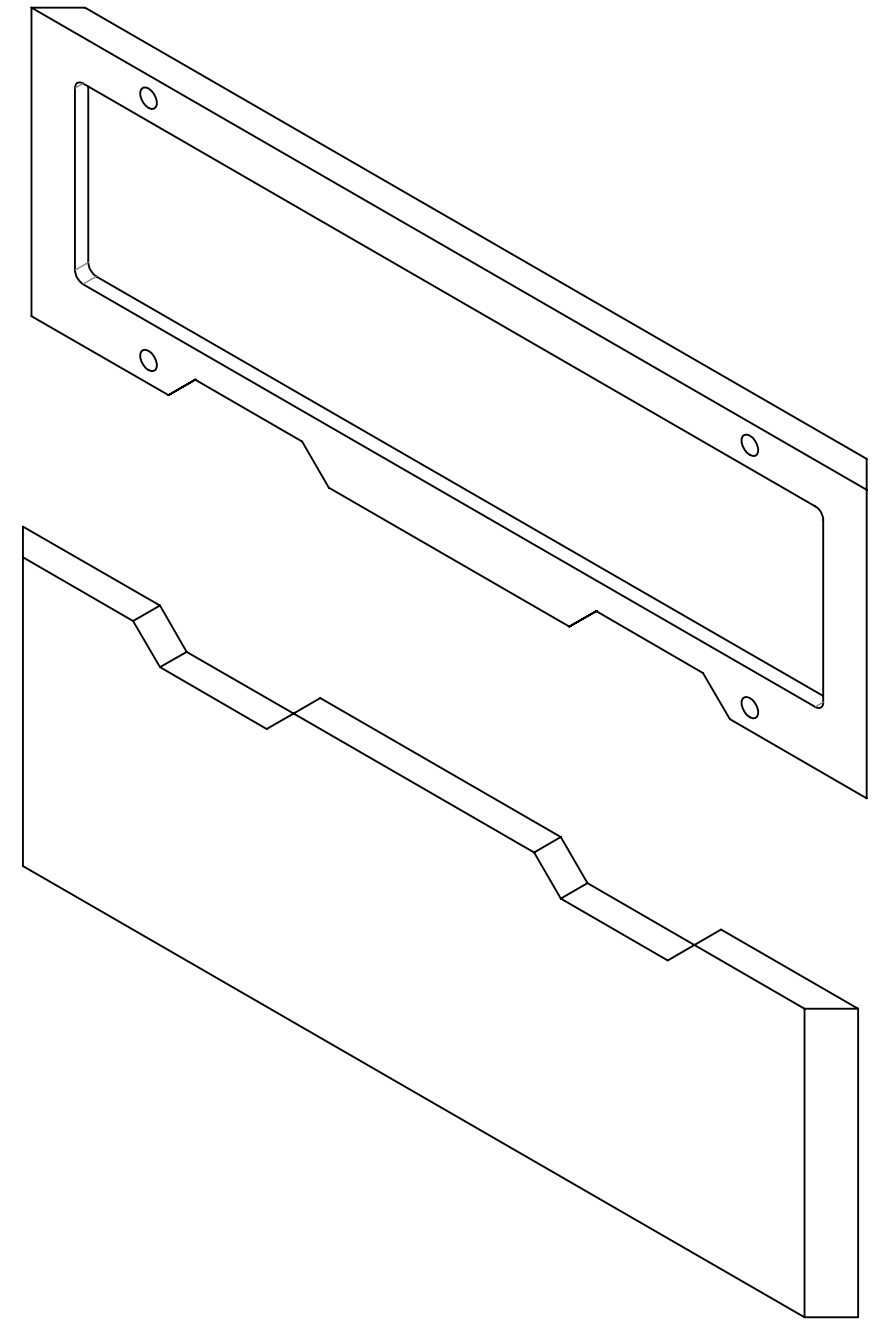
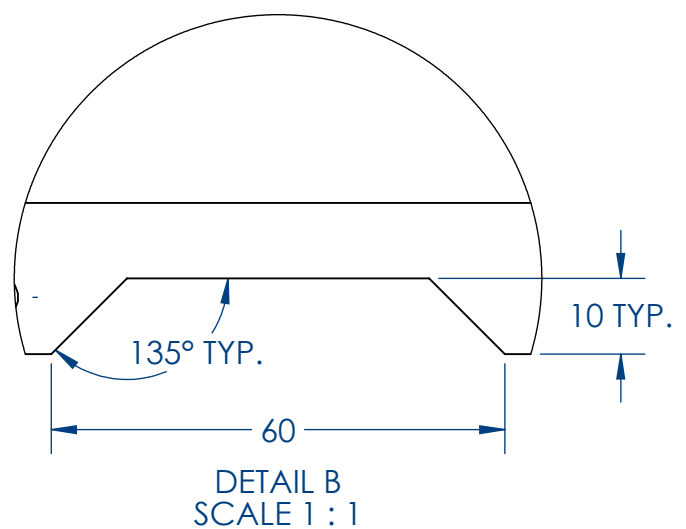
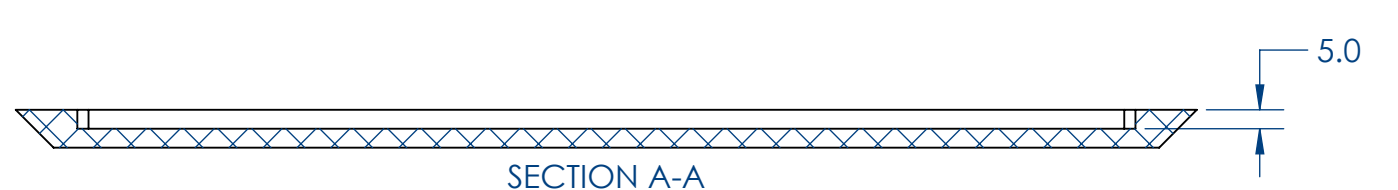
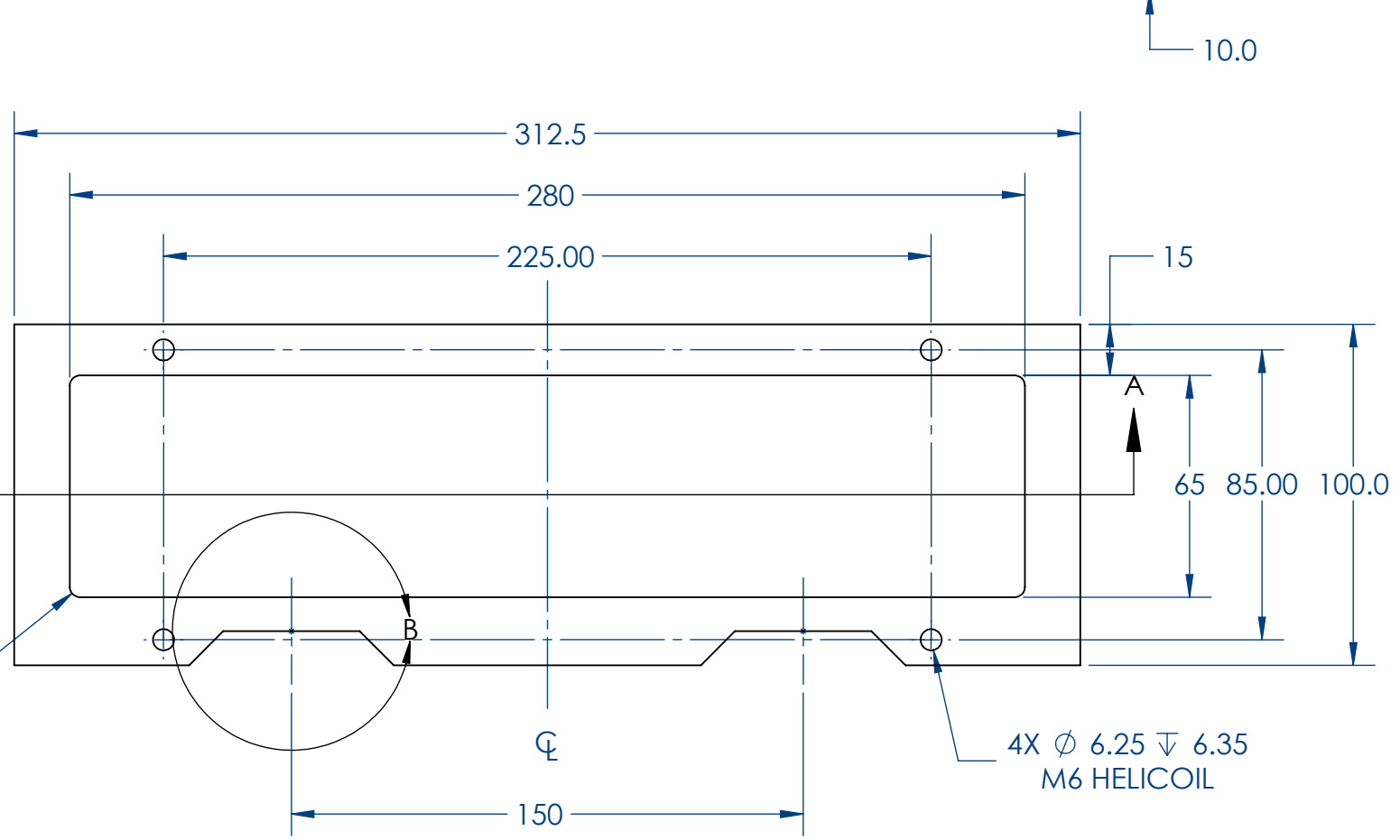
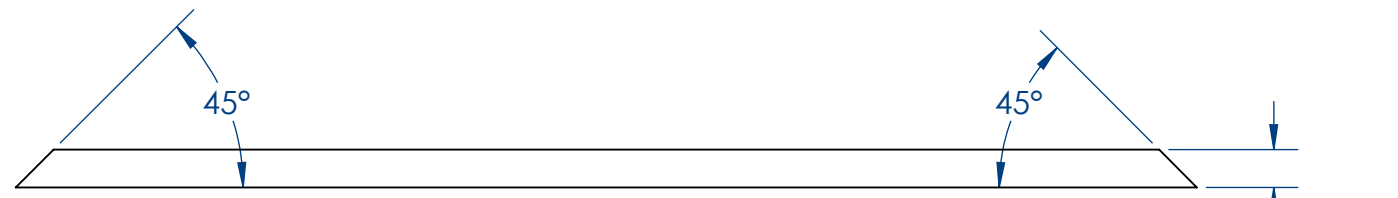

UNLESS OTHERWISE SPECIFIED: DIMENSIONS ARE IN MILLIMETRES X ± 0.25 XX ± 0.125 XXX ± 0.012	ANGULAR ± 0° 30'	METRIC	ALL FERROUS PARTS MUST BE DEMAGNETIZED	MATERIAL: DELRIN	MODEL REV:	DRAWING REV:
		DO NOT SCALE DRAWING	Miscellaneous			
GEOMETRIC DIMENSIONING AND TOLERANCING AS PER ASME Y14.5M-1994		Designed By: K.Sey	2021-06-04			
PROPERTY OF STACKPOLE INTERNATIONAL NOT TO BE REPRODUCED WITHOUT EXPRESSED AUTHORIZATION		Detailed By: K.Sey	2021-06-04			
THIRD ANGLE PROJECTION		Checked By:		TITLE: Back Spacer		
BREAK UNNECESSARY EDGES UNLESS OTHERWISE NOTED		Approved By:		DWG NO. 365-00-002-BACK-SPACER		
ADDITIONAL PROCESSES: COATING: NO - OTHER: NO -	WEIGHT: 282.96 TAGS:	MACHINE REFERENCE				
FINISH SURFACES TO UNLESS OTHERWISE NOTED		Ra 3.2		SCALE 1:1		
		STAMP DWG. NO. AND REV. LEVEL AT LOCATION MARKED		B SHEET 1 OF 1		

3

2

1

C:\Users\Kristin\Documents\From Lenovo\Stackpole International Projects\Sinter Furnace Loading Tool

ZONE	ECN NO.	REV.	REVISION DESCRIPTION	DATE	APPROVED
------	---------	------	----------------------	------	----------

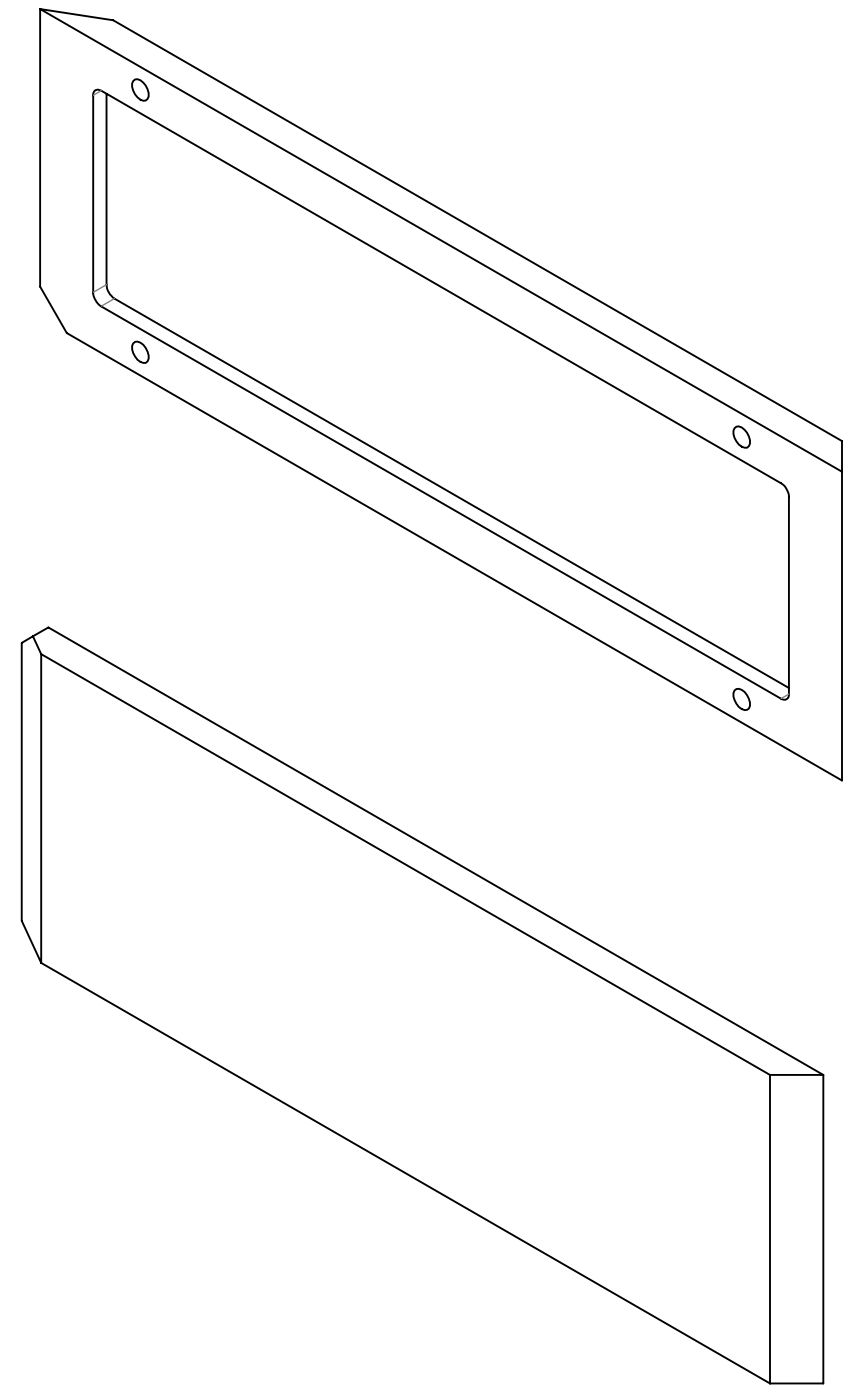
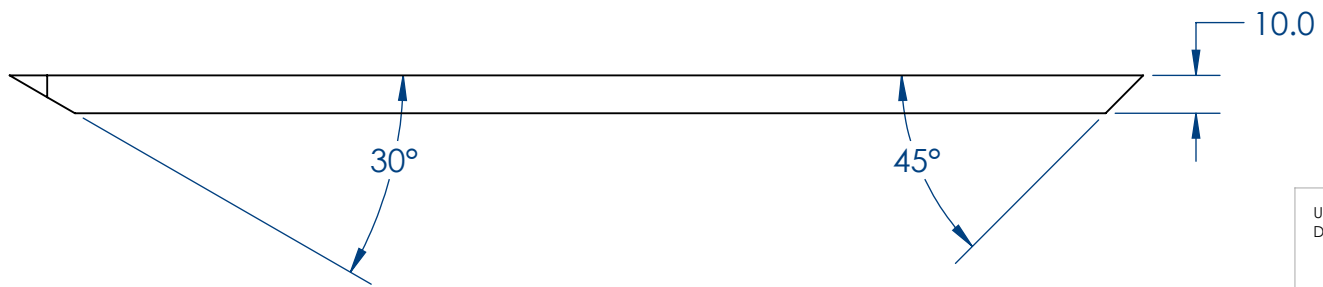
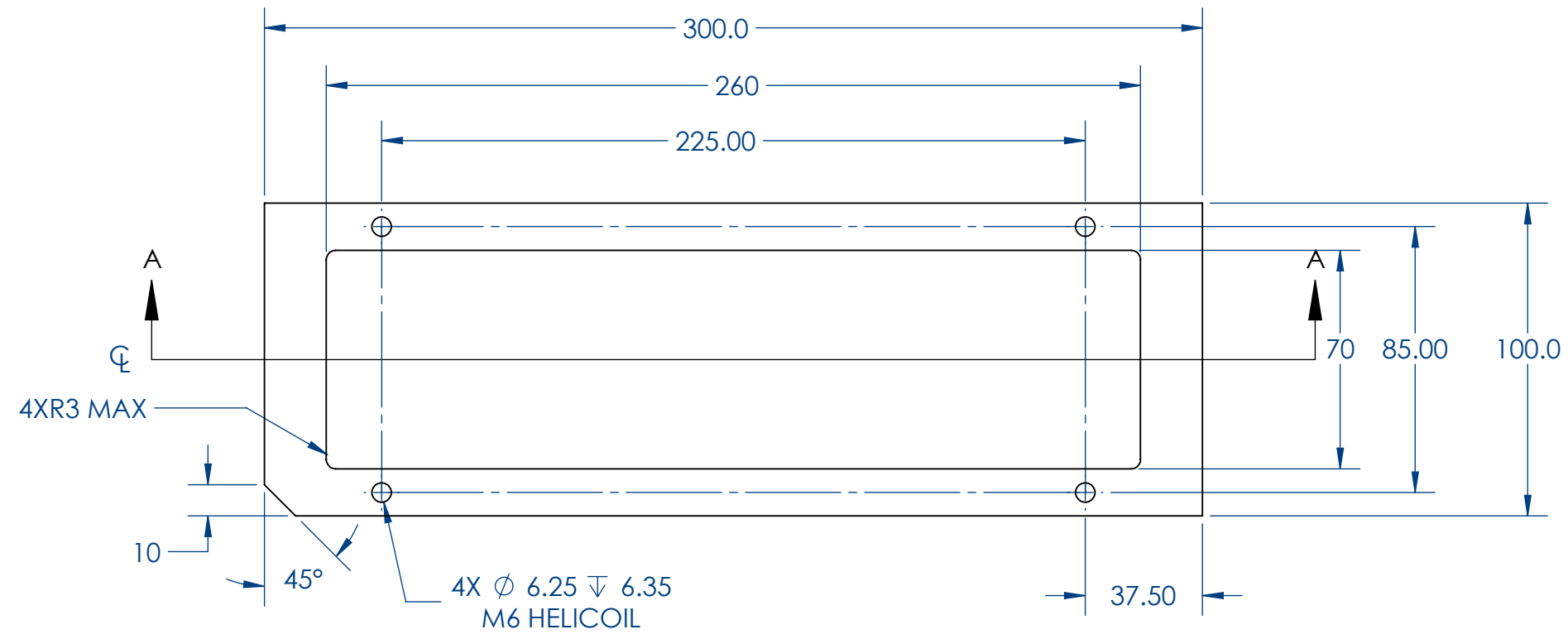
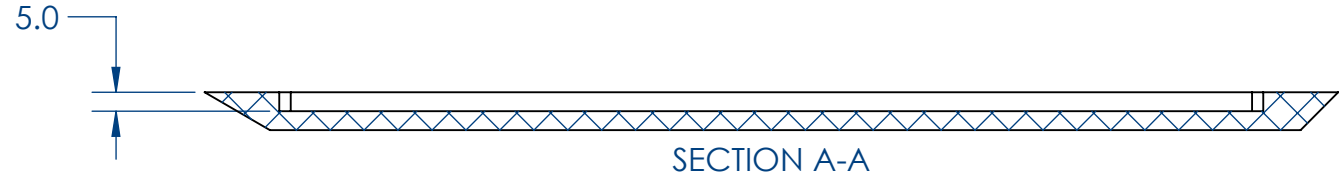

UNLESS OTHERWISE SPECIFIED: DIMENSIONS ARE IN MILLIMETRES X ± 0.25 XX ± 0.125 XXX ± 0.012	METRIC	ALL FERROUS PARTS MUST BE DEMAGNETIZED		MATERIAL: DELRIN	MODEL REV:	DRAWING REV:
	DO NOT SCALE DRAWING	Miscellaneous				
GEOMETRIC DIMENSIONING AND TOLERANCING AS PER ASME Y14.5M-1994		Designed By:	K.Sey	2021-06-04		
PROPERTY OF STACKPOLE INTERNATIONAL NOT TO BE REPRODUCED WITHOUT EXPRESSED AUTHORIZATION		Detailed By:	K.Sey	2021-06-04		
THIRD ANGLE PROJECTION 		Checked By:			TITLE: Left Side Spacer	
		Approved By:			DWG NO: 365-00-005-LEFT-SIDE-SPACER	
ADDITIONAL PROCESSES: COATING: NO - OTHER: NO -	WEIGHT: 274.24 TAGS:	BREAK UNNECESSARY EDGES UNLESS OTHERWISE NOTED 		MACHINE REFERENCE		
		FINISH SURFACES TO UNLESS OTHERWISE NOTED Ra 3.2		STAMP DWG. NO. AND REV. LEVEL AT LOCATION MARKED ↑		

ZONE	ECN NO.	REV.	REVISION DESCRIPTION	DATE	APPROVED
------	---------	------	----------------------	------	----------

D
C
B
A

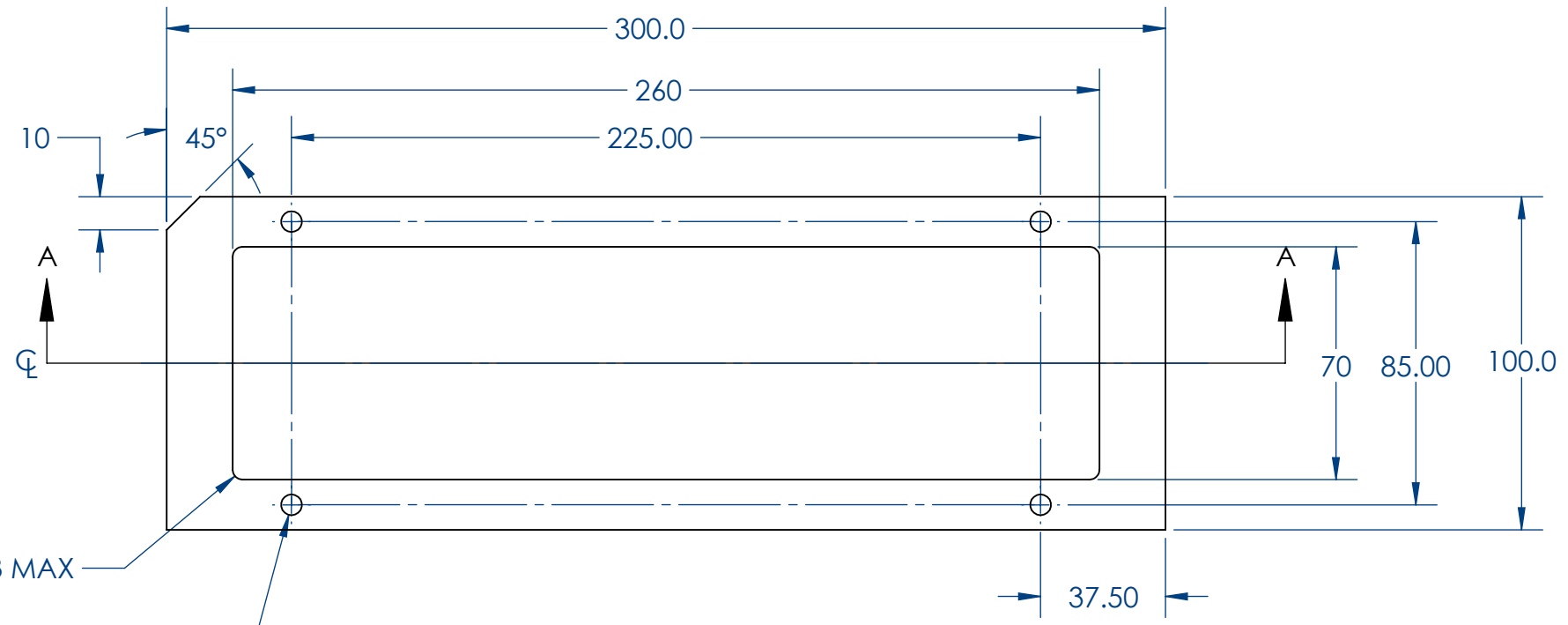
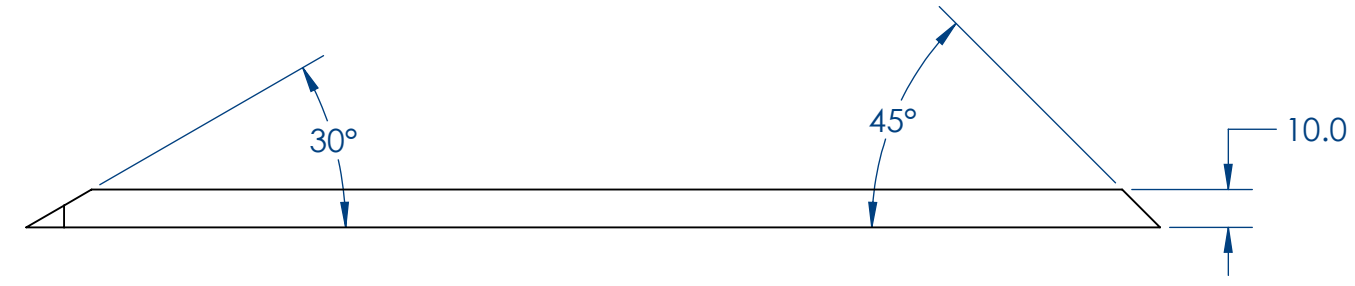

4XR3 MAX
4X ϕ 6.25 ∇ 6.35
M6 HELICOIL

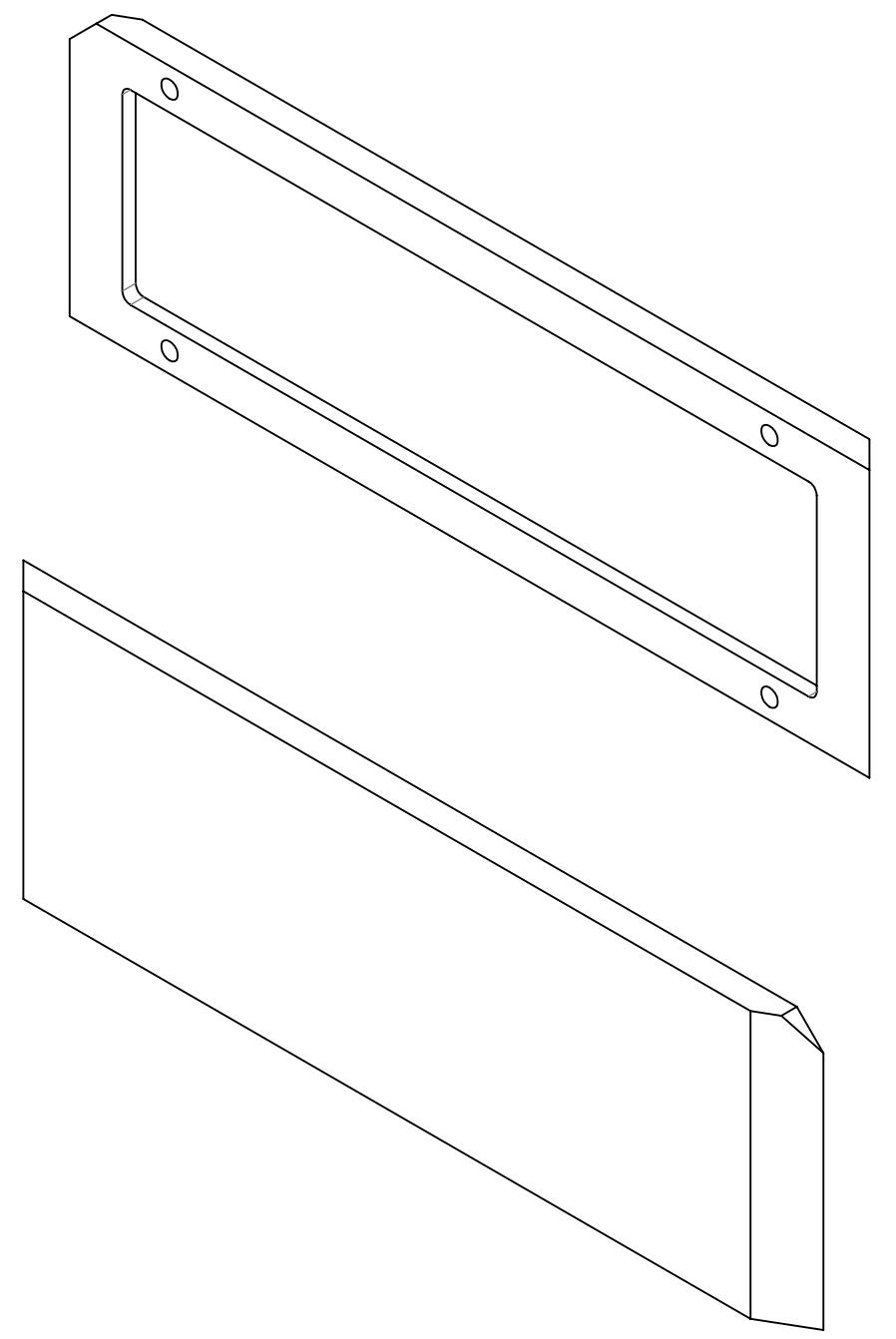
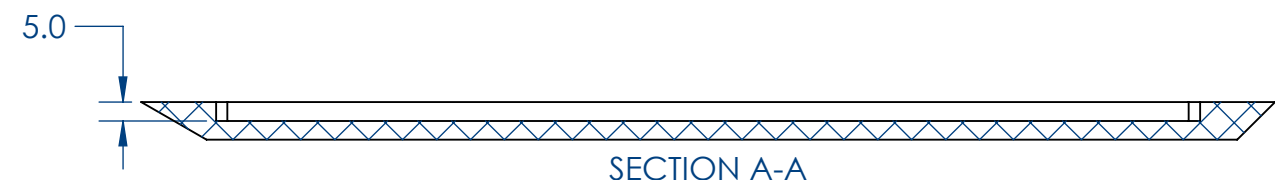

D
C
B
A

UNLESS OTHERWISE SPECIFIED: DIMENSIONS ARE IN MILLIMETRES X \pm 0.25 XX \pm 0.125 XXX \pm 0.012	METRIC DO NOT SCALE DRAWING	ALL FERROUS PARTS MUST BE DEMAGNETIZED		MATERIAL: DELRIN	MODEL REV:	DRAWING REV:
		Miscellaneous		TITLE: Right Side Spacer		
GEOMETRIC DIMENSIONING AND TOLERANCING AS PER ASME Y14.5M-1994		Designed By: K.Sey	2021-06-04	DWG NO: 365-00-005-RIGHT-SIDE-SPACER		
PROPERTY OF STACKPOLE INTERNATIONAL NOT TO BE REPRODUCED WITHOUT EXPRESSED AUTHORIZATION		Detailed By: K.Sey	2021-06-04	SCALE 1:1		
THIRD ANGLE PROJECTION		Checked By:		B		
BREAK UNNECESSARY EDGES UNLESS OTHERWISE NOTED		Approved By:		SHEET 1 OF 1		
FINISH SURFACES TO UNLESS OTHERWISE NOTED		MACHINE REFERENCE		July 18, 2022 2:31:59 PM		
ADDITIONAL PROCESSES: COATING: NO - OTHER: NO -		WEIGHT: 274.24 TAGS:		STAMP DWG. NO. AND REV. LEVEL AT LOCATION MARKED \blacktriangle		

ZONE	ECN NO.	REV.	REVISION DESCRIPTION	DATE	APPROVED
------	---------	------	----------------------	------	----------

4X Ø 6.60 ∇ 3.18

300

262.50

238.78

161.22

37.50

15.23

3X Ø 5.00 THRU ALL M6X1.0

0

7.50

14.45

18.00

44.45

74.45

92.50

110.42

130

45° TYP.

10 TYP.

3X Ø 4.20 THRU ALL M5X0.8

[.125]
3.18

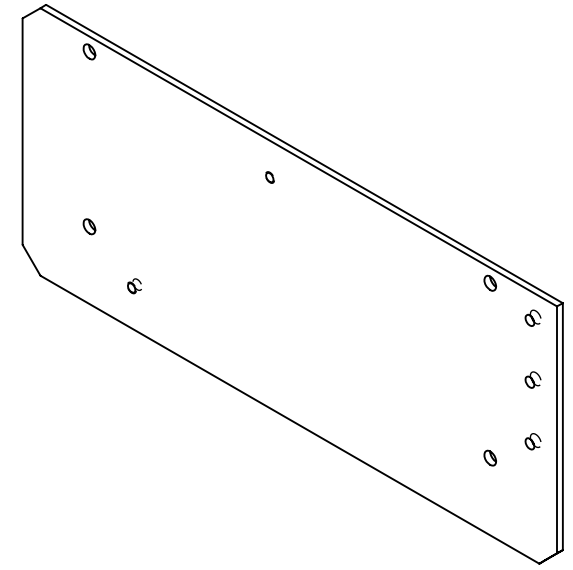

SCALE 1 : 3

UNLESS OTHERWISE SPECIFIED: DIMENSIONS ARE IN MILLIMETRES		METRIC		ALL FERROUS PARTS MUST BE DEMAGNETIZED		MATERIAL: 6061 ALUMINIUM		MODEL REV:	DRAWING REV:
X ± 0.25	ANGULAR ± 0° 30'	DO NOT SCALE DRAWING		Miscellaneous		TITLE: Side Wall			
XX ± 0.125				Designed By:	K.Sey				
XXX ± 0.012				Detailed By:	K.Sey	2021-06-04	DWG NO. 365-00-006-SIDE-WALL		
GEOMETRIC DIMENSIONING AND TOLERANCING AS PER ASME Y14.5M-1994				Checked By:					
PROPERTY OF STACKPOLE INTERNATIONAL NOT TO BE REPRODUCED WITHOUT EXPRESSED AUTHORIZATION				Approved By:			STAMP DWG. NO. AND REV. LEVEL AT LOCATION MARKED ↑		
THIRD ANGLE PROJECTION		BREAK UNNECESSARY EDGES UNLESS OTHERWISE NOTED		MACHINE REFERENCE		SCALE 2:3			
ADDITIONAL PROCESSES: COATING: NO - OTHER: NO -	WEIGHT: 367.92	FINISH SURFACES TO UNLESS OTHERWISE NOTED		Ra 3.2		SCALE 2:3		B	SHEET 1 OF 1

ZONE	ECN NO.	REV.	REVISION DESCRIPTION	DATE	APPROVED
------	---------	------	----------------------	------	----------

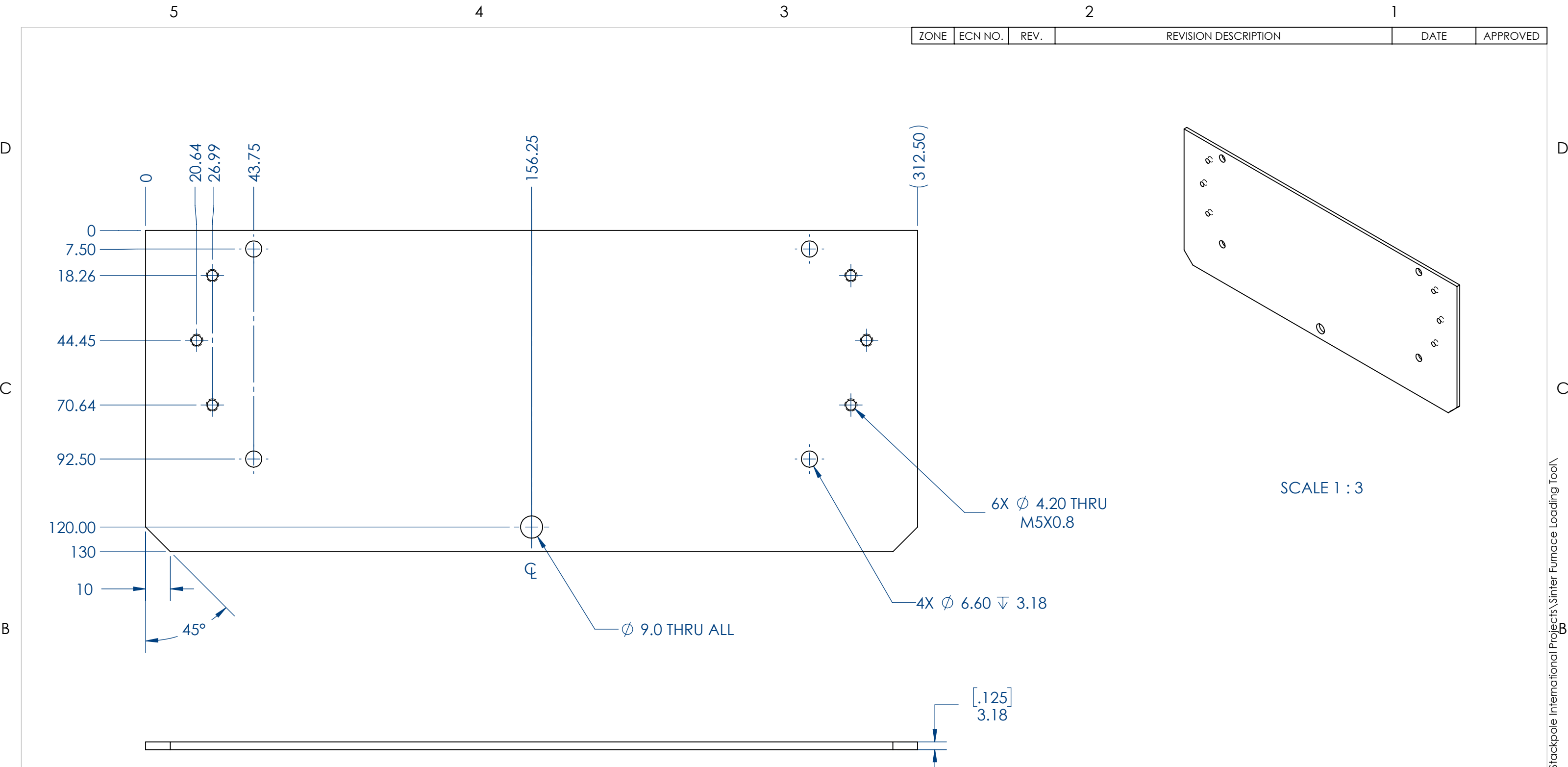

UNLESS OTHERWISE SPECIFIED: DIMENSIONS ARE IN MILLIMETRES X ± 0.25 XX ± 0.125 XXX ± 0.012	ANGULAR ± 0° 30'	METRIC	ALL FERROUS PARTS MUST BE DEMAGNETIZED		MATERIAL: 6061 ALUMINIUM	MODEL REV:	DRAWING REV:
		DO NOT SCALE DRAWING	Miscellaneous		TITLE: Back Wall		
GEOMETRIC DIMENSIONING AND TOLERANCING AS PER ASME Y14.5M-1994			Designed By:	K.Sey	2021-06-04	DWG NO. 365-00-007-BACK-WALL	
PROPERTY OF STACKPOLE INTERNATIONAL NOT TO BE REPRODUCED WITHOUT EXPRESSED AUTHORIZATION			Detailed By:	K.Sey	2021-06-04	SCALE 2:3	
THIRD ANGLE PROJECTION 			Checked By:			B	
			Approved By:			SHEET 1 OF 1	
ADDITIONAL PROCESSES: COATING: NO - OTHER: NO -			MACHINE REFERENCE		STAMP DWG. NO. AND REV. LEVEL AT LOCATION MARKED ↑		
WEIGHT: 383.30			BREAK UNNECESSARY EDGES UNLESS OTHERWISE NOTED 		July 18, 2022 2:31:59 PM		
TAGS:			FINISH SURFACES TO UNLESS OTHERWISE NOTED Ra 3.2				

5

4

3

2

1

REVISIONS					
ZONE	ECN.NO	REV.	DESCRIPTION	DATE	APPROVED

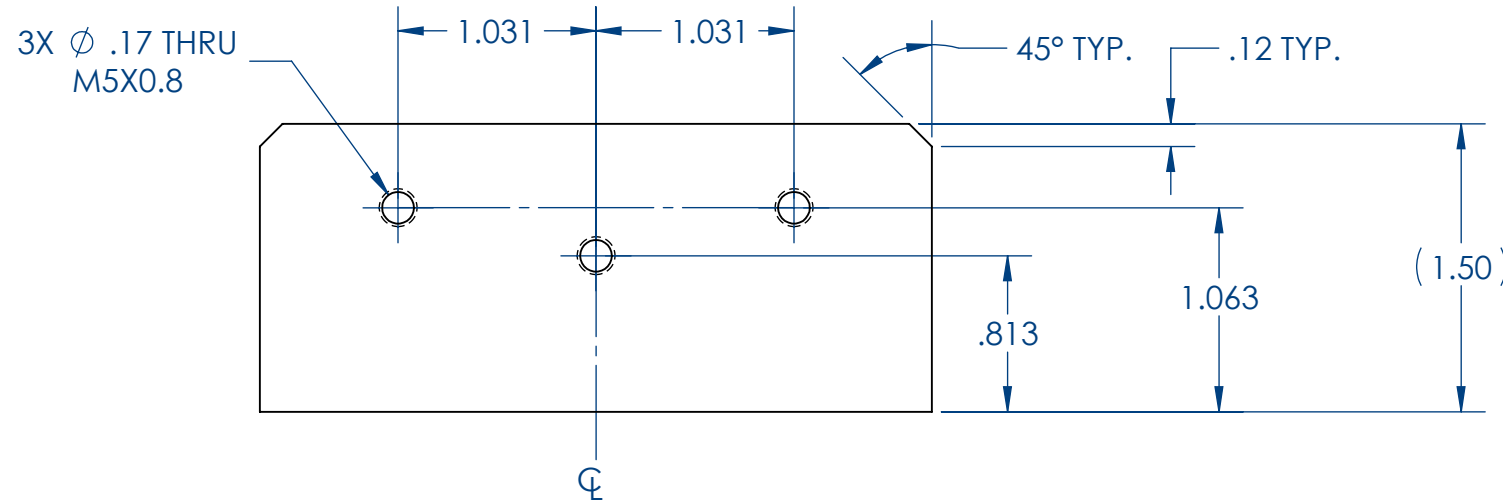
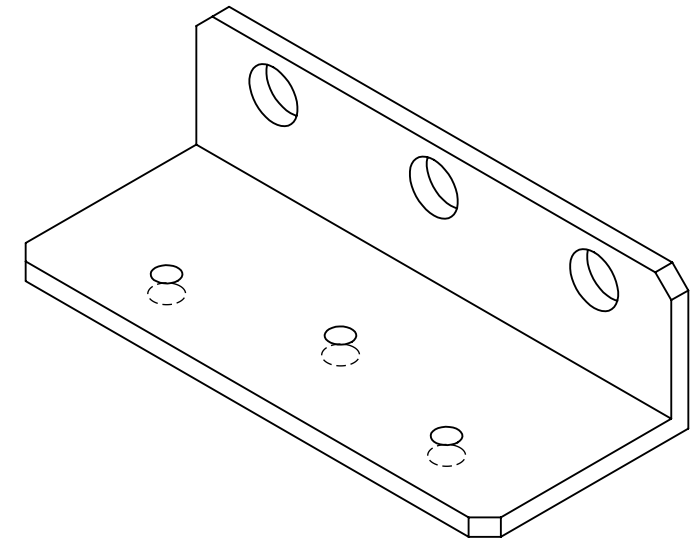
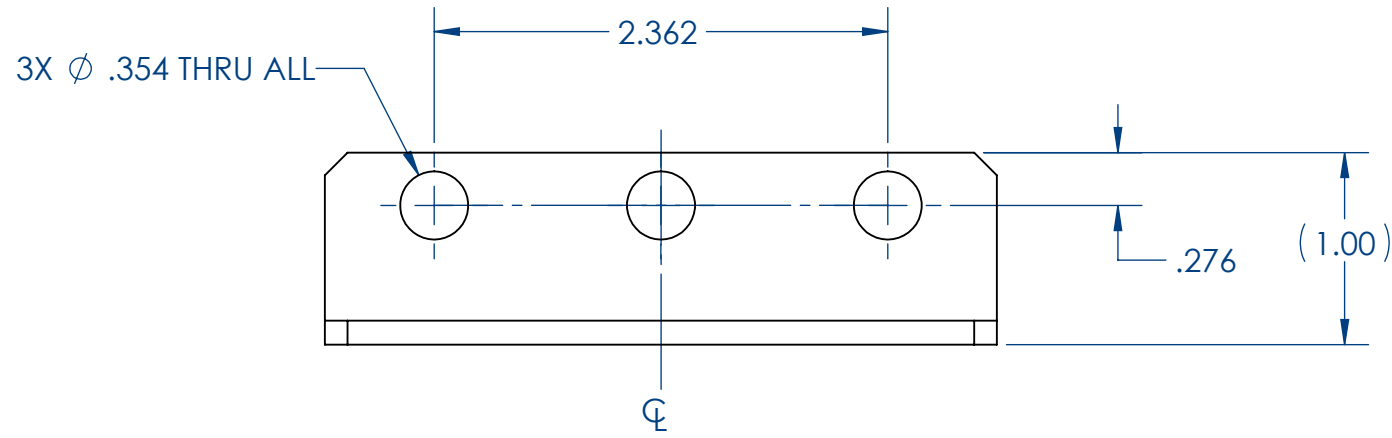

ITEM NO.	QTY.	DESCRIPTION	LENGTH
1	1	LS 1.50 X1.00 X 0.125	3.5

UNLESS OTHERWISE SPECIFIED: DIMENSIONS ARE IN INCHES X ± 0.1 XX ± 0.01 XXX ± 0.005 XXXX ± 0.0005	IMPERIAL DO NOT SCALE DRAWING	ALL FERROUS PARTS MUST BE DEMAGNETIZED		MATERIAL: 6061 ALUMINIUM	MODEL REV:	DRAWING REV:	
		GEOMETRIC DIMENSIONING AND TOLERANCING AS PER ASME Y14.5M-1994		Miscellaneous			
	PROPERTY OF STACKPOLE INTERNATIONAL NOT TO BE REPRODUCED WITHOUT EXPRESSED AUTHORIZATION		Designed By: K.Sey	2021-06-04	TITLE: Lifting Bracket		
	THIRD ANGLE PROJECTION		Detailed By: K.Sey	2021-06-04	DWG NO: 365-00-008-SPRING-HINGE-ANGLE-IRON		
ADDITIONAL PROCESSES: COATING: NO - OTHER: NO -	WEIGHT: 0.11 TAGS:	BREAK UNNECESSARY EDGES UNLESS OTHERWISE NOTED	FINISH SURFACES TO UNLESS OTHERWISE NOTED		MACHINE REFERENCE		

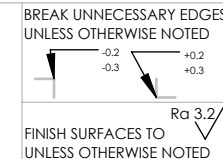
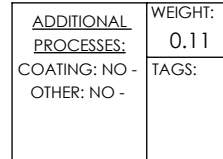

STAMP DWG. NO. AND REV. LEVEL AT LOCATION MARKED ↑ SCALE 1:1 B SHEET 1 OF 1

3

2

1

C:\Users\Kristin\Documents\From Lenovo\Stackpole International Projects\Sinter Furnace Loading Tool\